

### PIATTAFORMA ROTANTE REP 2-4,5 REP 2-4,5 ROTATING MANPLATFORM

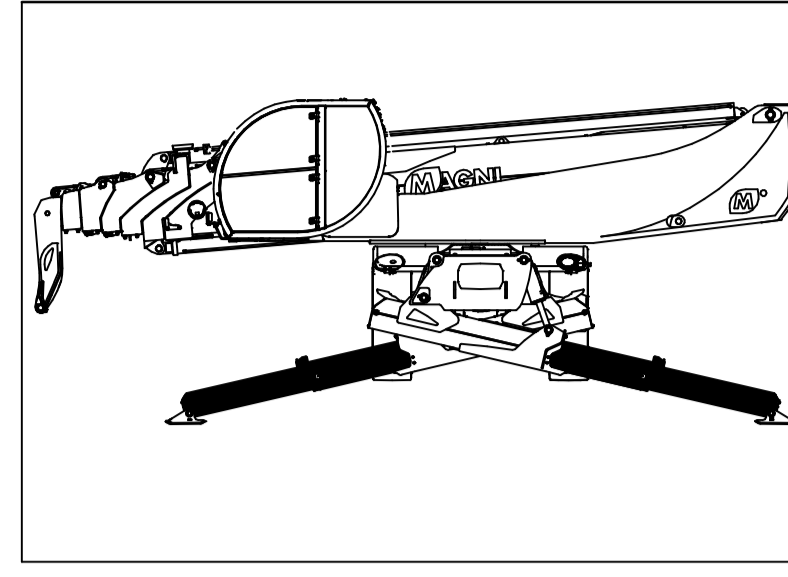

OUTRIGGERS 100%

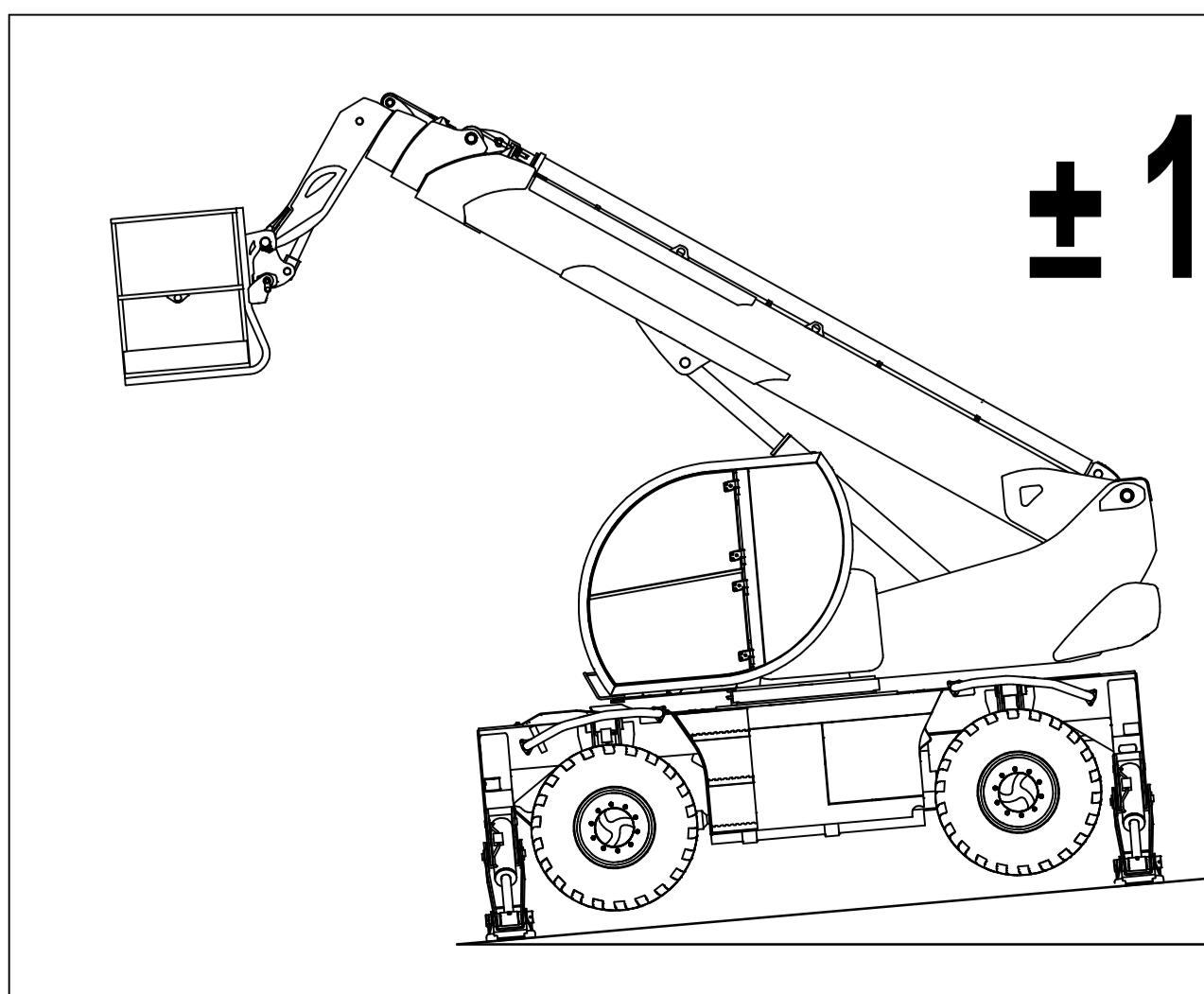
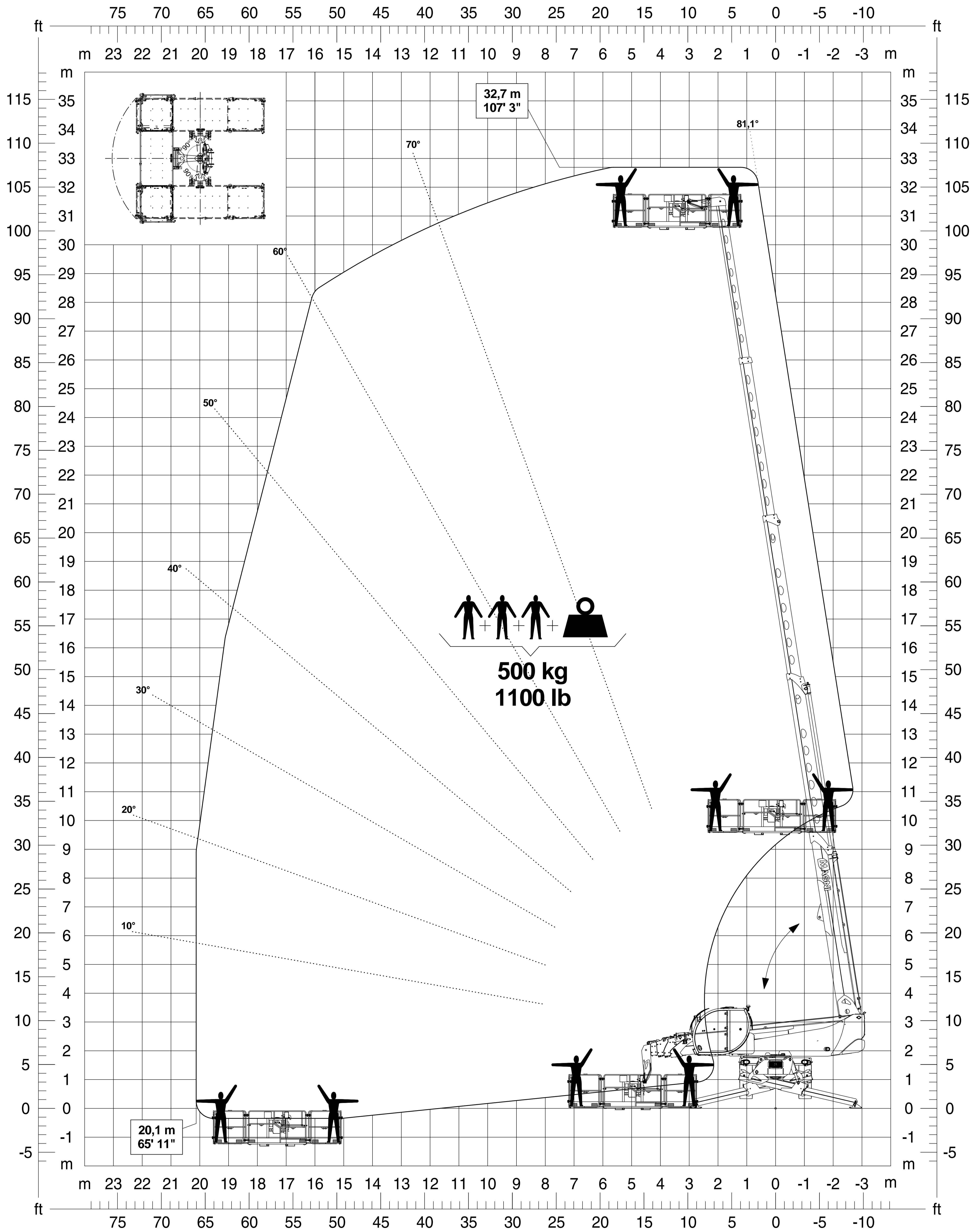
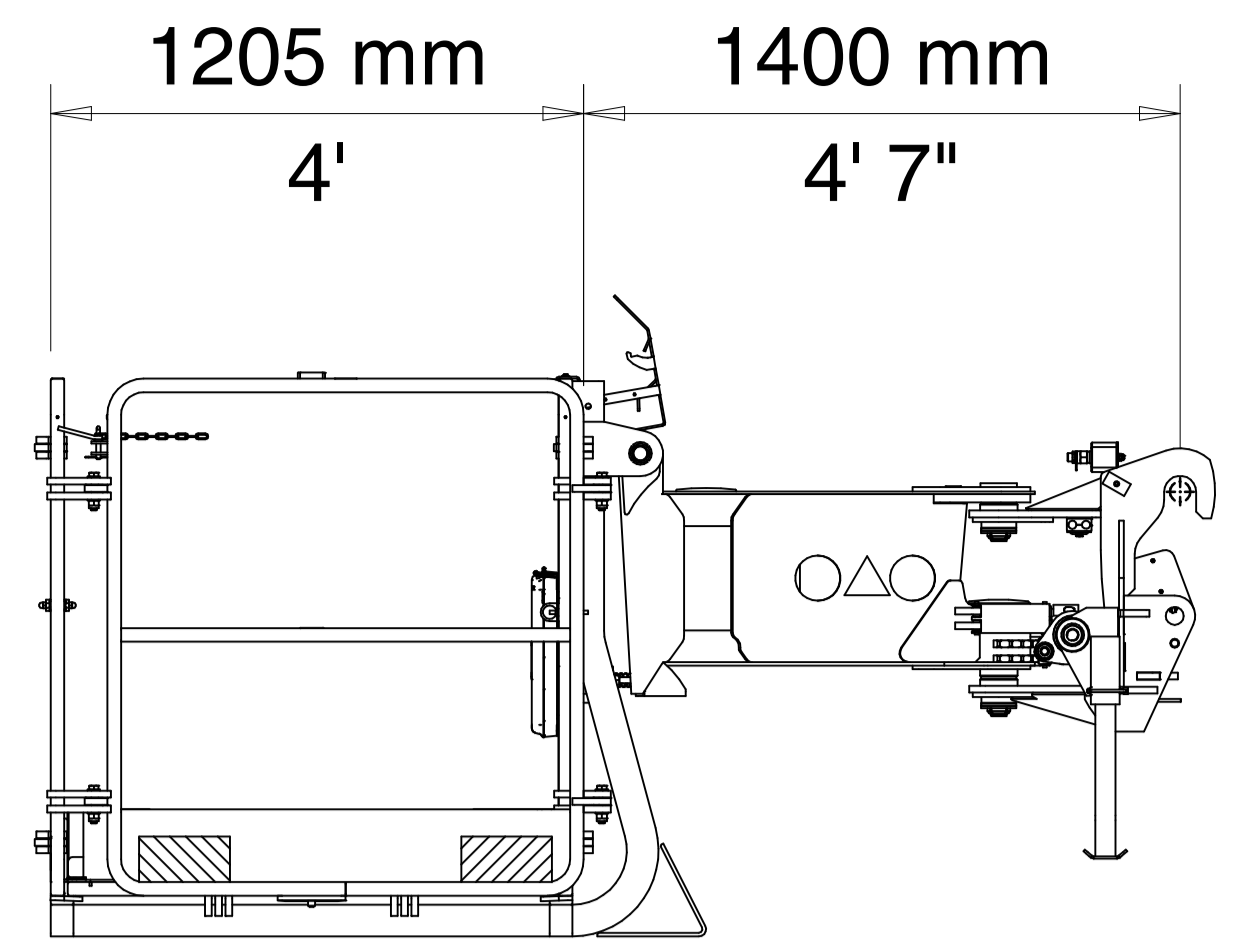

± 1°

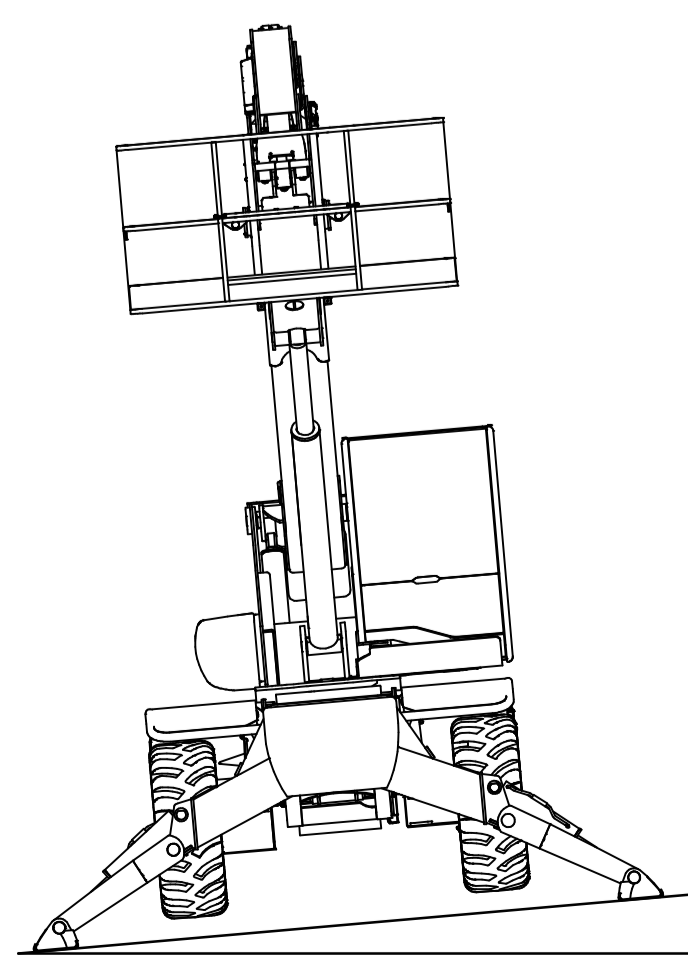

Standard Compliance:  
Solid Surface  
EN 280 / EN 280-1  
AS 1418.10

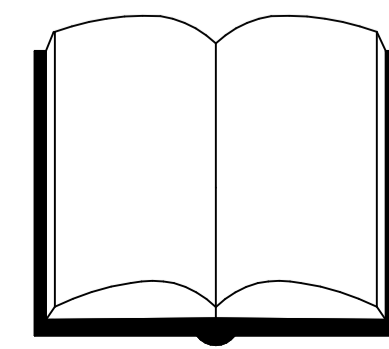

Wind speed

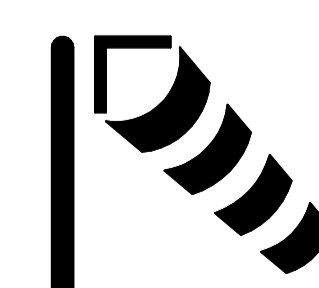

MAX  
45 km/h  
12,5 m/s

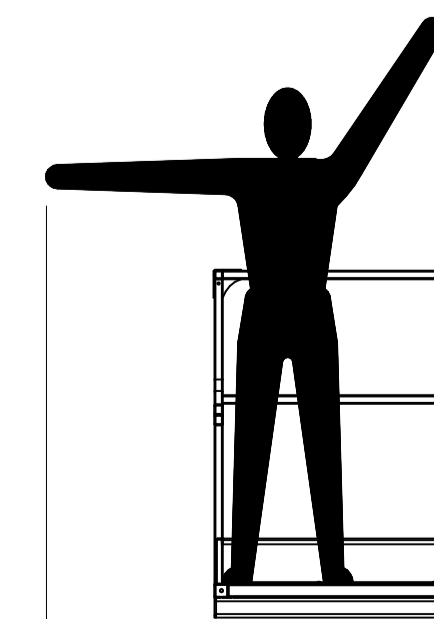

600 mm  
24"

REV: 0	MAGNI - MAGGI	MOD. N°: H-600	DATA DATE	REV. 0000	VERO. CHECK
SOLLECITAZIONE GENERALE - GENERAL SOLLECITAZIONE		SOLLECITAZIONE GENERALE - GENERAL SOLLECITAZIONE		SOLLECITAZIONE GENERALE - GENERAL SOLLECITAZIONE	
MATERIALE - MATERIAL		MATERIALE - MATERIAL		MATERIALE - MATERIAL	
DISEGNO N° - DRAW N°		DISEGNO N° - DRAW N°		DISEGNO N° - DRAW N°	
84621		84621		84621	